

July 6th, 2011

PCN for SMD kHz crystal, MC-146 taping and shipping spec

Dear Valued Customer:

Epson Toyocom maintains a continuous effort to improve the production and delivery performance of its product. We will change the taping pitch, reel diameter and packing style of MC-146 series. The details are follows.

1. Affected Products : SMD type kHz Crystal unit

- MC-146: Product code Q14MC146200**/Q14MC146200**/Q13MC146100**/Q13MC146200**

2. Change contents

(1) Crystal unit loading pitch of taping will be changed from 8mm to 4mm.

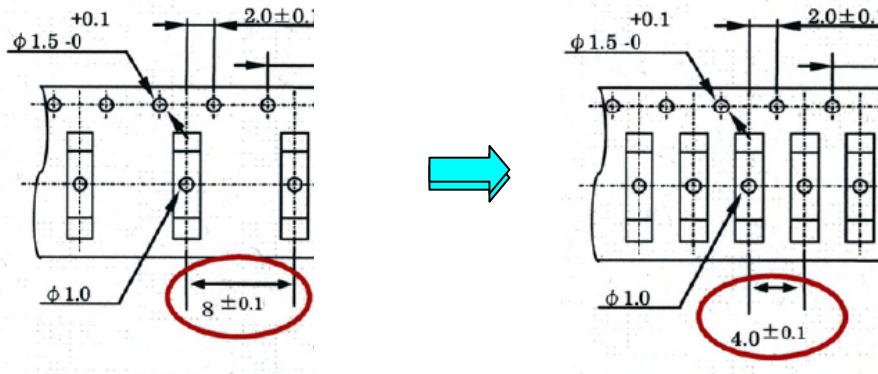

(2) Reel diameter changed from φ330mm to φ180mm.

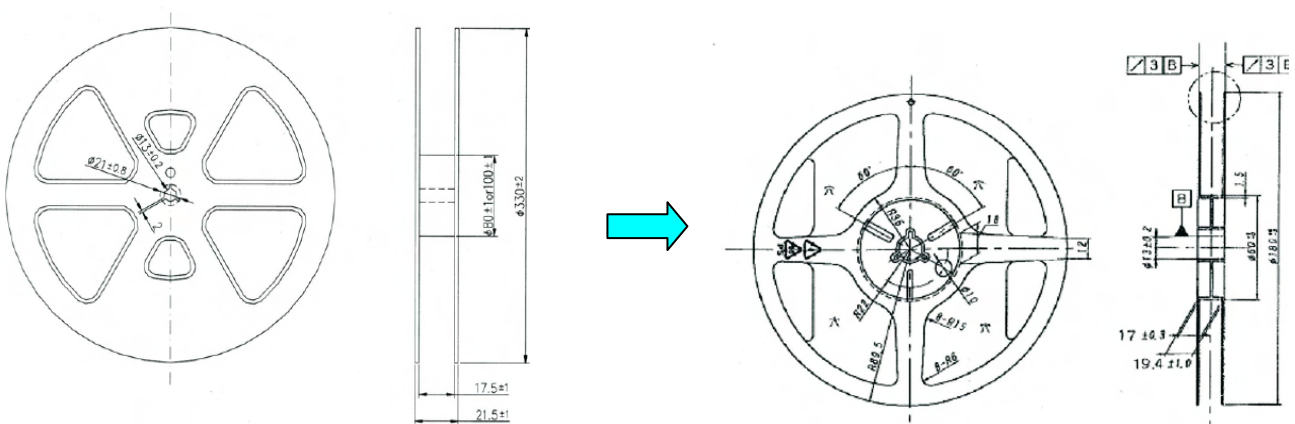

Reel diameter φ330mm

Reel diameter φ180mm

(3) Elimination of pizza box and direct in a shipping box with anti-static bag.

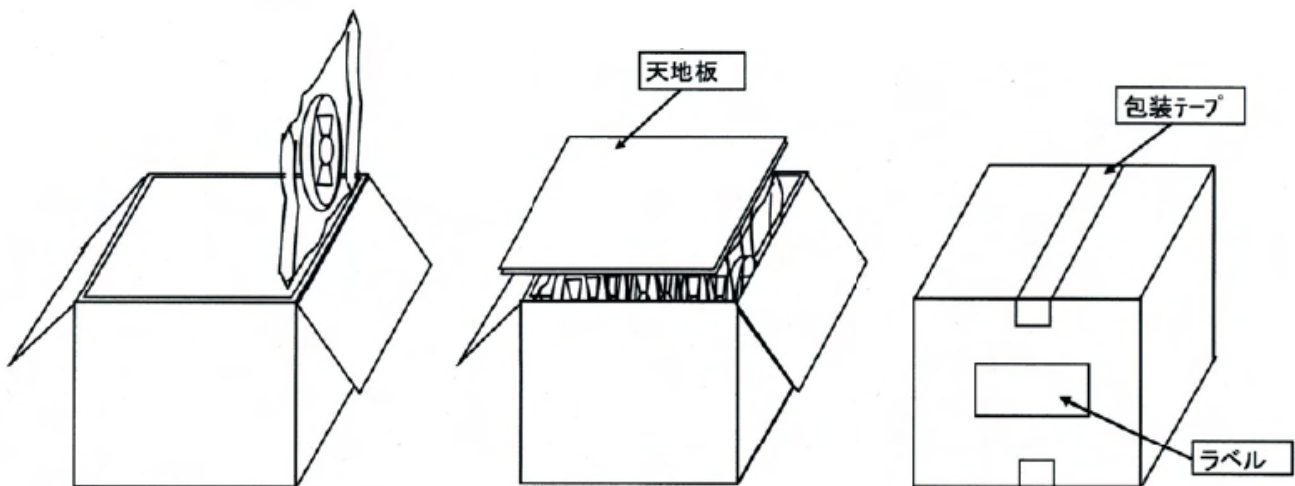
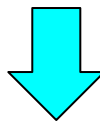
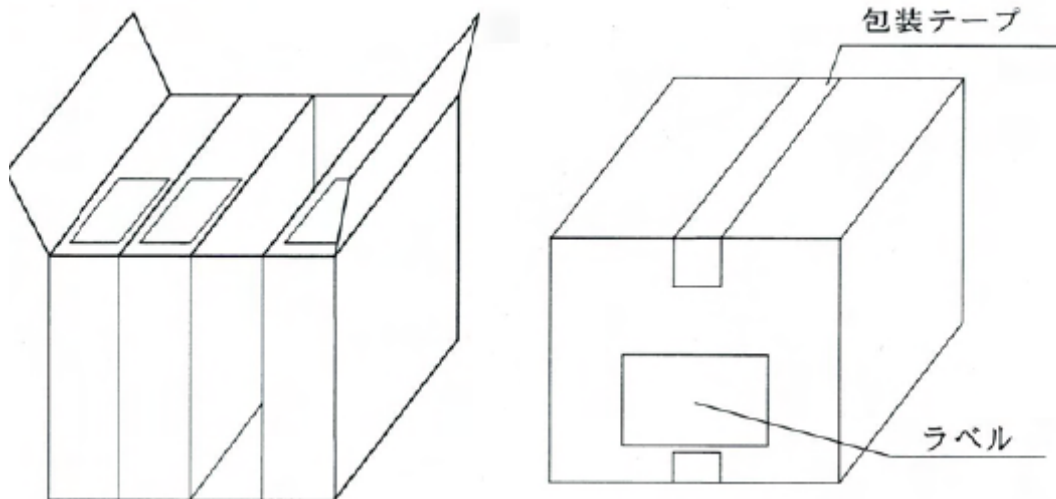

(4) The packing specification will be changed. If need to replace revised version, please let ETC sales person know.

3. Reason of change

This change is part of the environmental conservation activities based on the Seiko Epson Group's Environmental Philosophy. To implement this change will make the space saving of stock both of ETC and customers, shipping cargo space saving, and reduce of the industrial and trade waste at the customer site.

4. Schedule



Head Office:421-8 Hino, Hino-shi,
Tokyo 191-8501 Japan
Tel : 81-42-587-5878
Fax : 81-42-587-5564

We will start this taping and packing spec change affective from November/2011 shipping. If there are any concerns with this change, please discuss them with your local Epson Toyocom representative. When there is no response on this change, we determine that this PCN has been accepted. We appreciate your understanding.

Sincerely yours,